

High performance
vibration dampers

STANDARD MACHINE ELEMENTS WORLDWIDE

elesa®

High performance vibration dampers - Features and guidelines for the choice

General information

High performance vibration dampers are used in compliance with safety regulations on vibrations and noise (DL 81/2008). The use of this product range allows: to prevent damage to structures, to preserve the correct operation of sensitive equipment, to reduce noise.

Features

AVC:

- High static deflection, low resonance frequency and high vibration isolation.
- High damping, also suitable for machines with imbalances.
- Suitable for use with with compression, traction and shear.
- Suitable for applications where impacts and shocks may occur.
- Structure fully made out of stainless steel, resistant to flames, high temperatures and corrosion.

AVM:

- High static deflection depending on height, low resonance frequency and high vibration isolation.
- No damping factor, therefore not suitable for unbalanced machines.
- Suitable for use with with compression.
- Stainless steel springs must be used for temperatures below +5°C (special execution on request).

AVF:

- Heavy loads with moderate overall dimensions.
- Characterised by non-linear stiffness: vibration isolation in the first section of the curve, in the next section the system is stabilised for any overloads.
- Structure fully made out of stainless steel, resistant to flames, high temperatures and corrosion.

AVG:

- Good static deflection, low resonance frequency and good vibration isolation.
- High damping factor, also suitable for unbalanced machines.
- Suitable for use with with compression and traction.
- High safety degree: even in the case of the combustion of rubber resilient, the inner pin cannot come out of the structure and keeps the equipment securely suspended.

Guidelines for the choice

Analysis of the static tests to select the appropriate vibration damper.

Basic data required:

- The static load applied to each vibration damping element (acting on each support point).
- Disturbing frequency to be reduced and the desired isolation percentage.

How to choose the vibration-damping element:

- With reference to the diagram for the check of the isolation degree, locate the corresponding static deflection required to obtain the desired isolation.
- Select the product with the required static deflection depending on acting load.

Example:

Consider an application with the following features:

- Static load on each support: 1400 N
- Frequency to be isolated: 1.200 rpm = 20 Hz
- Required isolation: 90% at 20 Hz

For vibration dampers without damping e.g. AVM, the following diagram for checking the isolation degree shows that a static deflection of at least 7 mm is required to obtain 90% isolation of the 20 Hz frequency. In case of damping, the isolation percentage may vary, it is advisable to contact the Elessa Technical Department.

Diagram for checking the isolation degree of the vibration-damping element

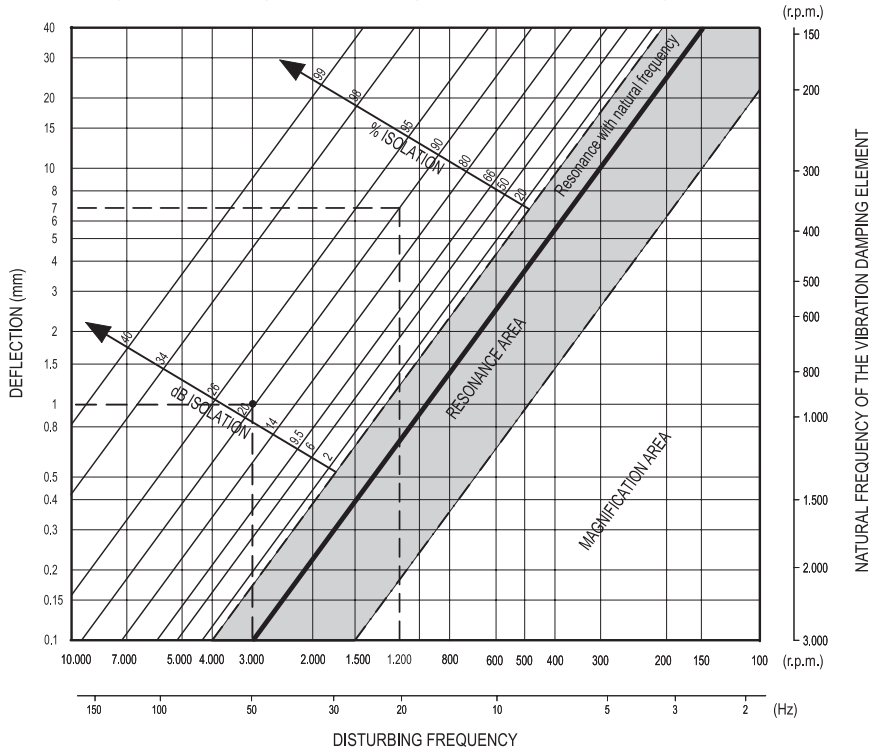

With reference to the graph below the products that intersect the 1400 N line are: AVF, AVG, AVM.
 For the 1400 N load, the expected static deflections are:

- AVF: approximately 4 mm (< 7 mm) = approximately 80% isolation at 20 Hz
- AVG: 6.5 mm (< 7 mm) = approximately 88% isolation at 20 Hz
- AVM: 13 mm (< 7 mm) = approximately 95% isolation at 20 Hz

Consequently, the most suitable product with the best isolation degree is AVM.

Example of load diagrams

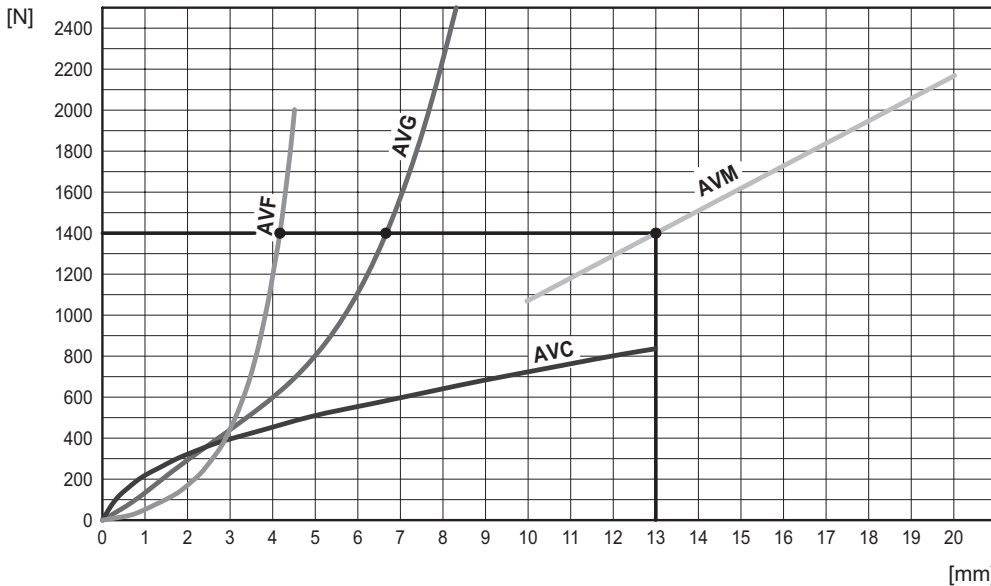

Simplified diagram for the check of the degree of isolation of a vibration damper

Deflec. [mm]	f0v [Hz]	Isolation %															
		1	15.9	-1%	-5%	-11%	-21%	-38%	-65%	-116%	-235%	-795%	-935%	-73%	32%	70%	89%
1.5	13.0	-2%	-7%	-17%	-36%	-70%	-145%	-416%	-1795%	-201%	-55%	27%	63%	82%	93%	96%	98%
2	11.3	-2%	-10%	-25%	-54%	-121%	-375%	-1239%	-148%	-29%	16%	54%	75%	87%	95%	97%	98%
2.5	10.1	-3%	-12%	-33%	-78%	-218%	-7569%	-191%	-33%	18%	43%	66%	81%	90%	96%	98%	99%
3	9.2	-3%	-15%	-42%	-111%	-463%	-442%	-63%	10%	40%	56%	73%	84%	92%	97%	98%	99%
4	8.0	-5%	-21%	-65%	-235%	-935%	-73%	13%	45%	61%	70%	81%	89%	94%	97%	99%	99%
5	7.1	-6%	-28%	-97%	-715%	-170%	-3%	41%	60%	71%	78%	85%	91%	95%	98%	99%	99%
6	6.5	-7%	-36%	-145%	-1795%	-55%	27%	55%	69%	77%	82%	88%	93%	96%	98%	99%	99%
7	6.0	-8%	-44%	-223%	-338%	-9%	43%	64%	74%	81%	85%	90%	94%	97%	99%	99%	99%
8	5.6	-10%	-54%	-375%	-148%	16%	54%	70%	78%	84%	87%	91%	95%	97%	99%	99%	Max
10	5.0	-12%	-78%	-7569%	-33%	43%	66%	77%	83%	87%	90%	93%	96%	98%	99%	99%	Max
12	4.6	-15%	-111%	-442%	10%	56%	73%	82%	87%	90%	92%	94%	97%	98%	99%	Max	Max
14	4.3	-18%	-159%	-162%	31%	65%	78%	85%	89%	91%	93%	95%	97%	98%	99%	Max	Max
16	4.0	-21%	-235%	-73%	45%	70%	81%	87%	90%	92%	94%	96%	97%	99%	99%	Max	Max
18	3.8	-25%	-375%	-29%	54%	75%	84%	88%	91%	93%	95%	96%	98%	99%	99%	Max	Max
20	3.6	-28%	-715%	-3%	60%	78%	85%	90%	92%	94%	95%	97%	98%	99%	99%	Max	Max
22	3.4	-32%	-2759%	15%	65%	80%	87%	91%	93%	95%	96%	97%	98%	99%	Max	Max	Max
25	3.2	-38%	-935%	32%	70%	83%	89%	92%	94%	95%	96%	97%	98%	99%	Max	Max	Max
30	2.9	-49%	-217%	49%	77%	86%	91%	93%	95%	96%	97%	98%	99%	99%	Max	Max	Max
32	2.8	-54%	-148%	54%	78%	87%	91%	94%	95%	96%	97%	98%	99%	99%	Max	Max	Max
35	2.7	-62%	-87%	59%	81%	88%	92%	94%	96%	97%	97%	98%	99%	99%	Max	Max	Max
40	2.5	-78%	-33%	66%	83%	90%	93%	95%	96%	97%	98%	98%	99%	99%	Max	Max	Max
45	2.4	-97%	-3%	71%	85%	91%	94%	96%	97%	97%	98%	99%	99%	99%	Max	Max	Max
50	2.3	-121%	16%	75%	87%	92%	95%	96%	97%	98%	98%	99%	99%	Max	Max	Max	Max
55	2.1	-152%	29%	77%	88%	93%	95%	96%	97%	98%	98%	99%	99%	Max	Max	Max	Max
60	2.1	-192%	39%	80%	90%	94%	96%	97%	98%	98%	98%	99%	99%	Max	Max	Max	Max
70	1.9	-330%	52%	83%	91%	95%	96%	97%	98%	98%	99%	99%	99%	Max	Max	Max	Max
80	1.8	-715%	60%	85%	92%	95%	97%	98%	98%	99%	99%	99%	99%	Max	Max	Max	Max
90	1.7	-7569%	66%	87%	93%	96%	97%	98%	98%	99%	99%	99%	99%	Max	Max	Max	Max
100	1.6	-935%	70%	89%	94%	96%	97%	98%	99%	99%	99%	99%	99%	Max	Max	Max	Max
150	1.3	-55%	82%	93%	96%	98%	98%	99%	99%	99%	99%	99%	99%	Max	Max	Max	Max
200	1.1	16%	87%	95%	97%	98%	99%	99%	99%	99%	99%	99%	99%	Max	Max	Max	Max
RPM		100	200	300	400	500	600	700	800	900	1000	1200	1500	2000	3000	4000	5000
[Hz]		1.7	3.3	5.0	6.7	8.3	10.0	11.7	13.3	15.0	16.7	20.0	25.0	33.3	50.0	66.7	83.3

■ No isolation

■ Minimum isolation

■ Average isolation

■ Resonance

■ Modest isolation

■ High isolation

CABLE, BARS AND SCREWS

AISI 316 stainless steel.

STANDARD EXECUTIONS

Threaded pass-through holes.

- **AVC-4**: the cable extends for four coils.
- **AVC-6**: the cable extends for six coils.
- **AVC-8**: the cable extends for eight coils.
- **AVC-10**: the cable extends for ten coils.

FEATURES AND APPLICATIONS

The wire rope isolators AVC comprise two pairs of bars, joined together by a connecting cable with a helical winding (coil).

They are generally used for isolating vibrations and shock absorption, where axial holding force, resistance to compression or shear is required.

Vibrations can cause:

- malfunctioning and reduction of the machine lifespan and/or of the adjacent ones;
- damage to health;
- noise.

They are particularly suitable for use with HVAC, pumps, purification and desalination plants, instrumentation panels, rail, naval and military. Some examples of application are shown in Fig.1.

See High performance vibration dampers - Characteristics and selection criteria (on page -).



SPECIAL EXECUTIONS ON REQUEST

- Vibration dampers with cable with AISI 304 stainless steel bars.
- Vibration dampers with cable with aluminium bars with chromium passivation.

Fig.1

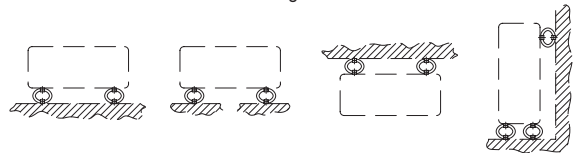

Description	Resistance to compression				Axial holding force				Resistance to shear			
	Min load [N]	Max load [N]	Min deflection [mm]	Max. deflection [mm]	Min load [N]	Max load [N]	Min deflection [mm]	Max. deflection [mm]	Min load [N]	Max load [N]	Min deflection [mm]	Max. deflection [mm]
AVC-4-4-53	50	110	2	5	50	110	1	3	20	40	5	10
AVC-4-4-64	45	90	2	6	45	90	3	5	10	33	5	13
AVC-4-6-61	200	300	2	4	200	300	2	3	70	150	3	7
AVC-4-6-93	70	140	2	7	70	140	3	6	30	70	5	13
AVC-4-7-110	80	180	2	9	80	180	2	8	30	90	5	17
AVC-4-8-80	370	660	2	6	370	660	2	4	100	270	4	12
AVC-4-10-80	850	1500	2	5	850	1500	1	3	400	900	4	11
AVC-4-10-108	300	630	2	7	300	630	2	6	150	300	5	14
AVC-4-13-102	1000	2500	2	8	1000	2500	2	5	500	1000	5	13
AVC-4-13-133	420	1060	2	11	420	1060	3	9	170	520	5	22
AVC-4-16-120	1260	3000	2	9	1260	3000	2	5	440	1780	4	18
AVC-4-16-152	680	1780	2	13	680	1780	3	9	340	1020	6	24
AVC-6-7-82	200	450	2	6	200	450	2	5	100	230	3	11
AVC-6-8-67	600	1000	2	4	600	1000	2	3	300	600	3	8
AVC-6-10-80	1500	2500	2	5	1500	2500	1	3	750	1400	5	11
AVC-6-10-140	380	660	4	10	380	660	4	8	85	300	5	26
AVC-6-13-90	1560	3480	2	6	1560	3480	1	3	550	1475	4	12
AVC-6-13-135	850	1500	4	11	850	1500	4	11	300	800	6	21
AVC-8-10-80	1300	2500	2	5	1300	2500	1	2	400	920	3	9
AVC-8-10-140	300	820	3	11	300	820	1	6	100	390	6	24
AVC-8-13-120	1500	3000	4	11	1500	3000	3	7	600	1500	7	19
AVC-8-13-145	1230	2080	4	12	1230	2080	4	8	540	1080	5	22
AVC-10-16-150	2400	4900	5	11	2400	4900	4	9	820	2000	5	20
AVC-10-16-185	1750	2800	6	16	1750	2800	6	12	280	1160	6	30

The min. load is the value below which the vibration damper is not able to isolate the vibrations as it would be too rigid.
 The max load is the value beyond which some type of failure may occur that compromises the functionality of the vibration damper.
 The min. deflection is the crushing of the vibration-damping support corresponding to the min. load.
 The max. deflection is the crushing of the vibration-damping support corresponding to the max. load.

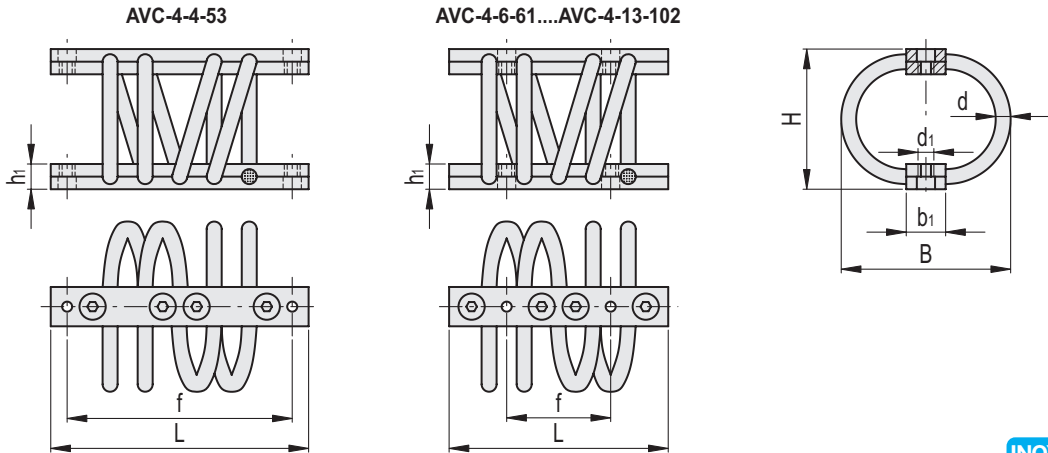

INOX STAINLESS STEEL

AVC-4

Code	Description	B	L	H	d	d6H	d1	h	s	f	⚖
480001	AVC-4-4-53	53 ±3	71	45 ±3	4	8	M6	15	8	61	154
480002	AVC-4-4-64	64 ±3	71	51 ±3	4	8	M6	15	12	61	170
480003	AVC-4-6-61	61 ±3	91	51 ±3	6	12	M6	15	12	46	305
480005	AVC-4-6-93	90 ±4	91	65 ±4	6	12	M6	15	12	46	420
480007	AVC-4-7-110	110 ±4	91	79 ±4	7	12	M6	15	12	46	443
480008	AVC-4-8-80	80 ±3	91	60 ±3	8	12	M6	15	12	46	435
480009	AVC-4-10-80	80 ±4	155	68 ±4	10	16	M8	25	16	83	1111
480011	AVC-4-10-108	108 ±4	155	89 ±4	10	16	M8	25	16	83	1241
480013	AVC-4-13-102	101 ±4	155	80 ±4	13	20	M8	25	20	83	1586
480014	AVC-4-13-133	133 ±3	155	108 ±3	13	20	M8	25	20	83	1765
480016	AVC-4-16-120	120 ±3	155	98 ±3	16	25	M10	25	25	83	2740
480018	AVC-4-16-152	152 ±3	155	117 ±3	16	25	M10	25	25	83	3120

AVC-6

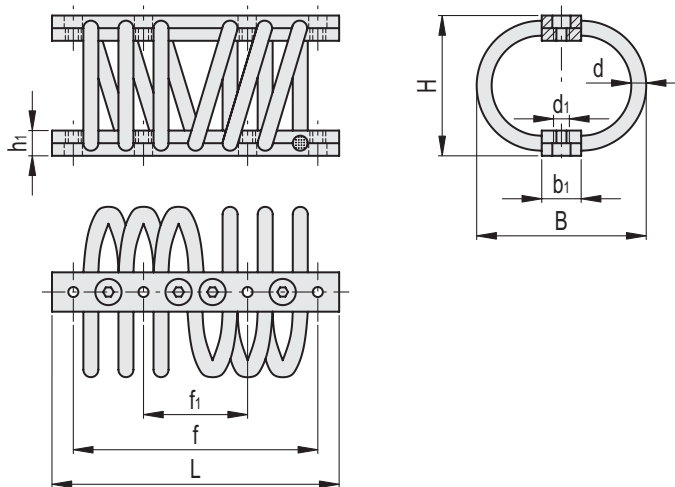

INOX STAINLESS STEEL

AVC-6

Code	Description	B	L	H	d	d6H	d1	h	s	f	f±5*	⚖
480021	AVC-6-7-82	82 ±4	200	60 ±4	7	12	M6	15	12	155	66	711
480023	AVC-6-8-67	67 ±4	200	53 ±4	8	12	M6	15	12	155	66	718
480025	AVC-6-10-80	80 ±4	169	68 ±4	10	16	M6	25	16	155	66	1272
480026	AVC-6-10-140	140 ±3	169	108 ±3	10	16	M6	25	16	155	66	1990
480027	AVC-6-13-135	135 ±5	178	110 ±5	13	20	M8	25	20	155.5	66.6	2610
480028	AVC-6-13-90	90 ±3	178	75 ±3	13	20	M8	25	20	155.5	66	2640

AVC-8

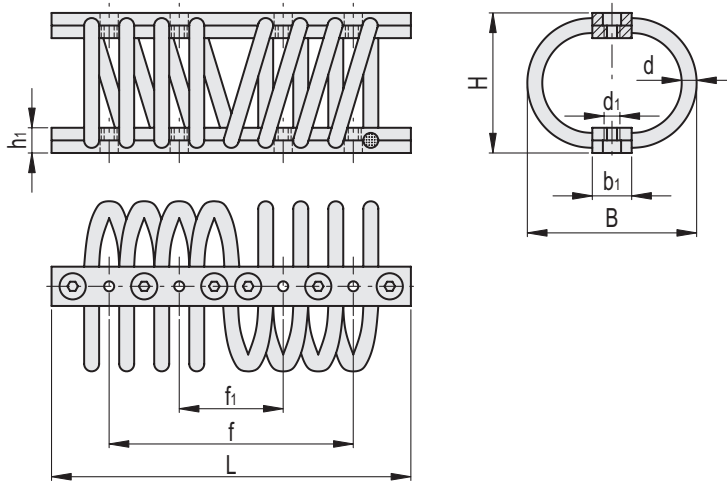

AVC-8



Code	Description	B	L	H	d	d6H	d1	d1 ±4	b1	h	h1	s	f	f±5*	f1	⚖
480029	AVC-8-13-120	118 ±4	222	95 ±4	13	20	M6	-	-	25	-	20	155	66	-	2670
480031	AVC-8-10-80	80 ±3	222	68 ±3	10	16	M6	M6	25	25	16	16	155	66	66	2010
480033	AVC-8-10-140	140 ±3	222	108 ±3	10	16	M6	M6	25	25	16	16	155	66	66	2620
480035	AVC-8-13-145	145 ±3	222	108 ±3	13	20	M6	M6	25	25	20	20	155	66	66	3520

AVC-10

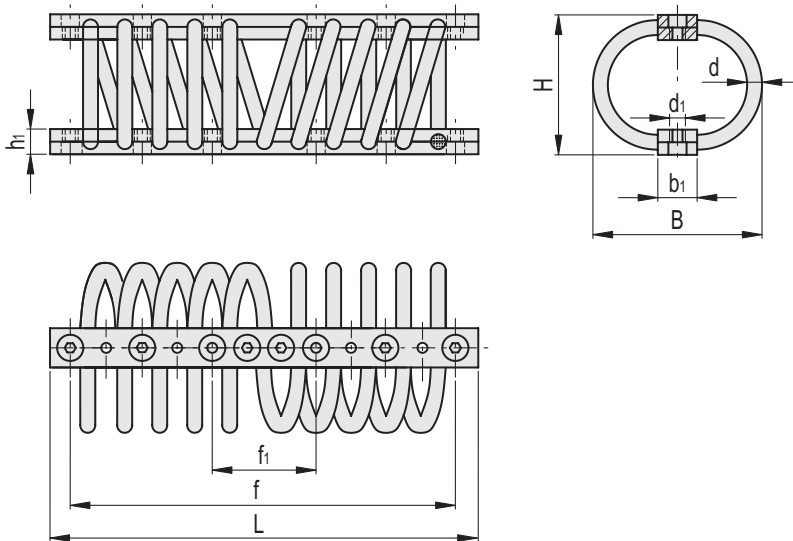

AVC-10



Code	Description	B	L	H	d	d6H	d1	d1 ±4	b1	h	h1	s	f	f±5*	f1	⚖
480041	AVC-10-16-150	150 ±3	363	120 ±3	16	25	M10	M10	25	25	25	25	274.5	152.5	152.5	7300
480043	AVC-10-16-185	185 ±3	363	145 ±3	16	25	M10	M10	25	25	25	25	274.5	152.5	152.5	8350

SPRINGS AND PLATES

Zinc-plated steel.

BODY AND NO-SLIP COATING

NBR rubber.

Hardness 60 Shore A ± 5 .

FEATURES AND APPLICATIONS

They are particularly suitable for use with HVAC, compressors, refrigeration units, centrifuges, crushers, vibrating screens and generators.

They are generally used for vibration isolation in compression.

Vibrations can cause:

- malfunctioning and reduction of the machine lifespan and/or of the adjacent ones;
- damage to health;
- noise.

See High performance vibration dampers - Characteristics and selection criteria (on page -).

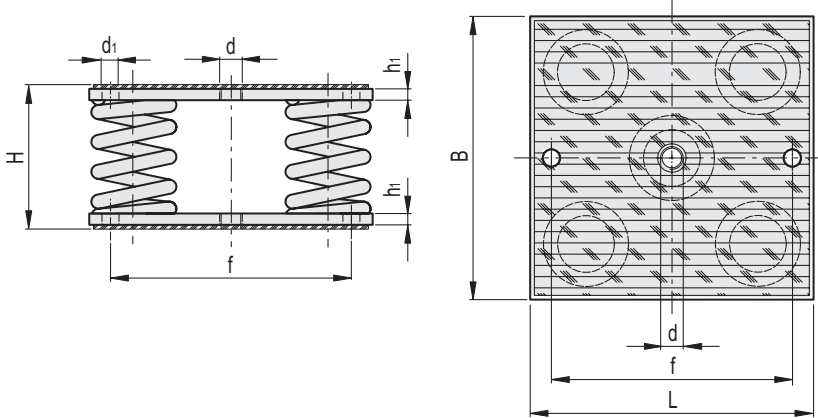

Code	Description	B	L	H	d	d1	h1	f	Min load [N]	Max load [N]	Min deflection [mm]	Max. deflection [mm]	Δ
480161	AVM.4-2P-80-60	140	140	102	M16	12	8	110	320	600	10	20	4000
480162	AVM.4-2P-80-140	140	140	102	M16	12	8	110	600	1400	10	20	4000
480163	AVM.4-2P-80-220	140	140	102	M16	12	8	110	1080	2200	10	20	4000
480164	AVM.4-2P-80-320	140	140	102	M16	12	8	110	1600	3200	10	20	4000
480165	AVM.4-2P-80-400	140	140	102	M16	12	8	110	2000	4000	10	20	4000
480166	AVM.4-2P-80-560	140	140	102	M16	12	8	110	2800	5600	10	20	4000
480167	AVM.4-2P-80-700	140	140	102	M16	12	8	110	3600	7200	10	20	4000
480168	AVM.4-2P-80-860	140	140	102	M16	12	8	110	4200	8600	10	20	4000
480169	AVM.4-2P-80-1400	140	140	102	M16	12	8	110	7000	14000	10	20	4100
480170	AVM.4-2P-80-2050	140	140	102	M16	12	8	110	13700	20500	10	15	4100

The min. load is the value below which the vibration damper is not able to isolate the vibrations as it would be too rigid.

The max load is the value beyond which some type of failure may occur that compromises the functionality of the vibration damper.

The min. deflection is the crushing of the vibration-damping support corresponding to the min. load.

The max. deflection is the crushing of the vibration-damping support corresponding to the max. load.

MATERIAL

Zinc-plated steel.

FEATURES

To mount the AVM.4 (on page -), to the structure or machinery.

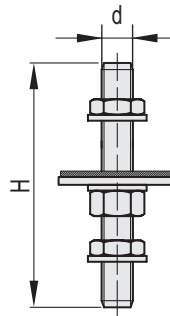

Code	Description	H	d	
480251	MAVM-M16x125	125	M16	150

BODY AND NO-SLIP COATING

NBR rubber.
Hardness 60 Shore A ±5.

SPRING AND PLATE

Zinc-plated steel.

SPRING CAPS

Aluminium.

FEATURES AND APPLICATIONS

AVM spring mounts comprise a body and a non-slip coating fixed to the lower part with a zinc-plated screw, and a spring on which two caps with pass-through holes at the ends are fixed.

They are generally used for vibration isolation in compression.

Vibrations can cause:

- malfunctioning and reduction of the machine lifespan and/or of the adjacent ones;
- damage to health;
- noise.

They are particularly suitable for use with HVAC, compressors, refrigeration units, centrifuges, crushers, vibrating screens and generators.

See High performance vibration dampers - Features and guidelines for the choice (on page -).



SPECIAL EXECUTIONS ON REQUEST

- Vibration dampers with one spring, with pins or threaded holes with a baseplate.
- Vibration dampers with spring, with two plates.
- Vibration dampers with spring, with one or two plates and pins for transport.

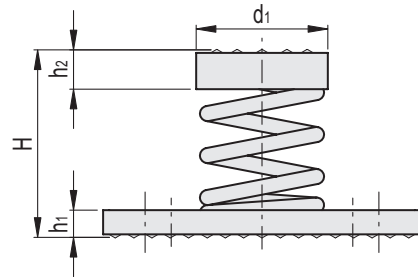
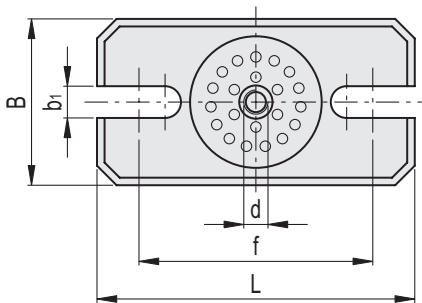

Code	Description	B	L	H	d	d1	b1	h1	h2	f±5*	Min load [N]	Max load [N]	Min deflection [mm]	Max. deflection [mm]	△
480121	AVM-50-13	55	105	62	M8	43.5	10.5	9	13	75	50	130	5	15	360
480123	AVM-50-25	55	105	62	M8	43.5	10.5	9	13	75	80	250	5	15	370
480125	AVM-50-35	55	105	62	M8	43.5	10.5	9	13	75	120	350	5	15	380
480127	AVM-50-50	55	105	62	M8	43.5	10.5	9	13	75	180	500	5	15	400
480129	AVM-50-80	55	105	62	M8	43.5	10.5	9	13	75	270	800	5	15	380
480131	AVM-50-115	55	105	62	M8	43.5	10.5	9	13	75	400	1150	5	15	430
480133	AVM-50-135	55	105	62	M8	43.5	10.5	9	13	75	450	1350	5	15	420
480135	AVM-50-155	55	105	62	M8	43.5	10.5	9	13	75	600	1550	5	13	450
480137	AVM-50-200	55	105	62	M8	48	10.5	9	18	75	850	2000	5	12	470
480141	AVM-80-15	55	105	92	M8	43.5	10.5	9	13	75	80	150	10	20	360
480143	AVM-80-35	55	105	92	M8	43.5	10.5	9	13	75	150	350	10	20	370
480145	AVM-80-55	55	105	92	M8	43.5	10.5	9	13	75	270	550	10	20	380
480147	AVM-80-80	55	105	92	M8	43.5	10.5	9	13	75	400	800	10	20	400
480149	AVM-80-100	55	105	92	M8	43.5	10.5	9	13	75	500	1000	10	20	490
480151	AVM-80-140	55	105	92	M8	43.5	10.5	9	13	75	700	1400	10	20	450
480153	AVM-80-175	55	105	92	M8	43.5	10.5	9	13	75	900	1750	10	20	490
480155	AVM-80-215	55	105	92	M8	48	10.5	9	18	75	1050	2150	10	20	530
480157	AVM-80-350	55	105	92	M8	48	10.5	9	18	75	1750	3500	10	20	610
480159	AVM-80-510	55	105	92	M8	48	10.5	9	18	75	3400	5100	10	15	650

* Fixing holes centre distance.

The min. load is the value below which the vibration damper is not able to isolate the vibrations as it would be too rigid.

The max load is the value beyond which some type of failure may occur that compromises the functionality of the vibration damper.

The min.deflection is the crushing of the vibration-damping support corresponding to the min. load.

The max.deflection is the crushing of the vibration-damping support corresponding to the max. load.

MESH

AISI 304 stainless steel.

STANDARD EXECUTIONS

- **AVF-A**: plain pass-through hole.
- **AVF-SH**: plain pass-through hole for countersunk-head screws.

FEATURES AND APPLICATIONS

They are generally used for vibration isolation in compression.

Vibrations can cause:

- malfunctioning and reduction of the machine lifespan and/or of the adjacent ones;
- damage to health;
- noise.

They are particularly suitable for use with thrusters, electromechanical equipment, industrial refrigerants, pipe supports, flooring and train carriage panelling.

See High performance vibration dampers - Characteristics and selection criteria (on page -).



AVF-A

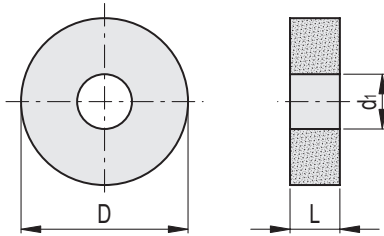

AVF-SH

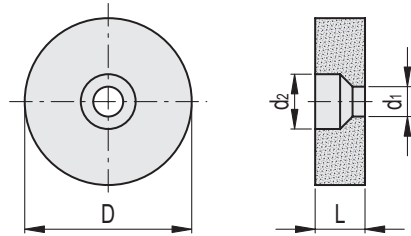

AVF-A



Code	Description	D ±4	L ±4	d1 ±4	Min load [N]	Max load [N]	Min deflection [mm]	Max. deflection [mm]	⚖️
480071	AVF-42-10-100-A-16	42	10	16	300	1000	3	4	30
480051	AVF-42-30-100-A-16	42	30	16	300	1000	8	12	60
480073	AVF-42-10-250-A-16	42	10	16	300	2500	2	3	50
480053	AVF-42-20-250-A-16	42	20	16	300	2500	4	7	60
480075	AVF-67-10-800-A-40	67	10	40	1200	8000	2	3	70
480055	AVF-67-20-800-A-40	67	20	40	1200	8000	3	5	140
480077	AVF-67-10-2000-A-30	67	10	30	3000	20000	2	3	80
480057	AVF-67-22-2000-A-30	67	22	30	3000	20000	5	8	190
480079	AVF-98-12-4000-A-39	98	12	39	4000	40000	3	5	200
480059	AVF-98-26-4000-A-39	98	26	39	4000	40000	6	9	410
480081	AVF-150-15-6500-A-49	150	15	49	8000	65000	7	9	590
480061	AVF-150-30-6500-A-49	150	30	49	8000	65000	8	11	950
480083	AVF-183-15-9300-A-68	183	15	68	10000	93000	7	9	770
480063	AVF-183-32-9300-A-68	183	32	68	10000	93000	9	13	1380
480065	AVF-225-35-15000-A-46	225	35	46	20000	150000	12	16	2450

AVF-SH



Code	Description	D ±4	L ±4	d1 ±4	d2 ±4	Min load [N]	Max load [N]	Min deflection [mm]	Max. deflection [mm]	⚖️
480091	AVF-42-30-100-SH-10	42	30	10	16	300	1000	6	10	60
480093	AVF-42-20-250-SH-10	42	20	10	16	300	2500	2	6	60
480095	AVF-67-20-800-SH-12	67	20	12	20	1200	8000	4	7	150
480097	AVF-67-22-2000-SH-12	67	22	12	20	3000	20000	5	8	150
480099	AVF-98-26-4000-SH-16	98	26	16	30	4000	40000	7	10	300

The min. load is the value below which the vibration damper is not able to isolate the vibrations as it would be too rigid.
 The max load is the value beyond which some type of failure may occur that compromises the functionality of the vibration damper.
 The min.deflection is the crushing of the vibration-damping support corresponding to the min. load.
 The max.deflection is the crushing of the vibration-damping support corresponding to the max. load.

MESH

AlSI 304 stainless steel.

PLATES

Hardened and tempered steel C43.

FEATURES AND APPLICATIONS

The recess on the upper plate allows for use with adjustment screws. The no-slip plate is shaped to prevent the product from slipping on the floor.

Generally used on machine tools for the isolation of compression vibrations.

Vibrations can cause:

- malfunctioning and reduction of the machine lifespan and/or of the adjacent ones;
- damage to health;
- noise.

Suitable for applications at high temperatures or in the presence of oils. See High performance vibration dampers Features and guidelines for the choice (on page -).

The deflection curves shown in the graph were obtained through static experimental tests adopting average values. Actual values may differ by approximately ±10% from those shown in the graph.

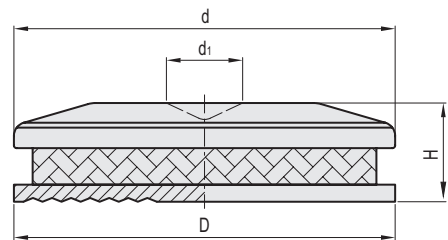
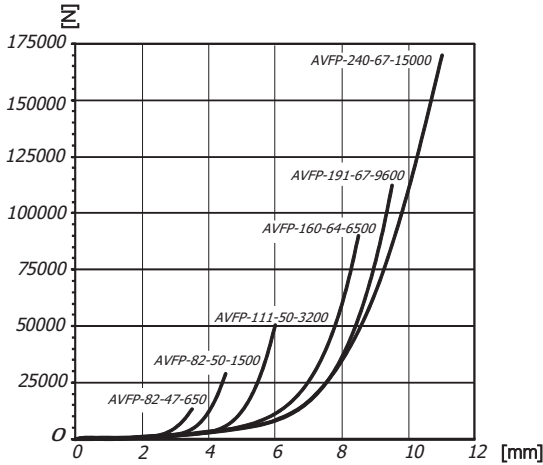

Code	Description	D	H	d	d1	Min load [N]	Max load [N]	⚖️
480261	AVFP-82-47-650-AS	81	47	82	18	2000	6500	1200
480263	AVFP-82-50-1500-AS	81	50	82	18	5000	15000	1200
480265	AVFP-111-50-3200-AS	111	50	111	25	13000	32000	2200
480267	AVFP-160-64-6500-AS	168	64	160	28	28000	65000	5600
480269	AVFP-191-67-9600-AS	198	67	191	30	55000	96000	9300
480271	AVFP-240-67-15000-AS	240	67	240	28	80000	150000	13500

The min. load is the value below which the vibration damper is not able to isolate the vibrations as it would be too rigid. The max load is the value beyond which some type of failure may occur that compromises the functionality of the vibration damper.

MESH

AISI 304 stainless steel.

PLATES

Hardened and tempered steel C43.

FEATURES AND APPLICATIONS

The recess on the upper plate allows for use with adjustment screws. The no-slip plate is shaped to prevent the product from slipping on the floor.

Generally used on machine tools for the isolation of compression vibrations.

Vibrations can cause:

- malfunctioning and reduction of the machine lifespan and/or of the adjacent ones;
- damage to health;
- noise.

Suitable for applications at high temperatures or in the presence of oils. See High performance vibration dampers Features and guidelines for the choice (on page -).

The deflection curves shown in the graph were obtained through static experimental tests adopting average values.

Actual values may differ by approximately ±10% from those shown in the graph.

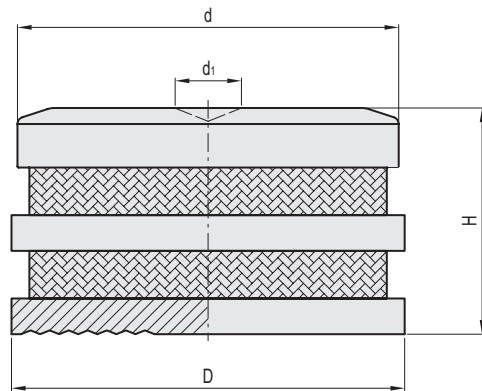
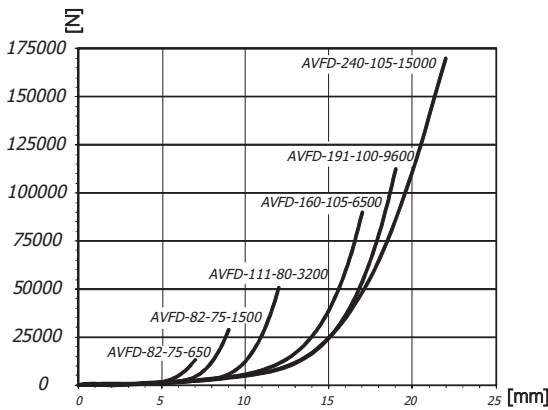

Code	Description	D	H	d	d1	Min load [N]	Max load [N]	⚖️
480273	AVFD-82-75-650-AS	81	75	82	18	2000	6500	1300
480275	AVFD-82-75-1500-AS	81	75	82	18	5000	15000	1400
480277	AVFD-111-80-3200-AS	112	80	111	25	13000	32000	2800
480279	AVFD-160-105-6500-AS	168	105	160	28	28000	65000	7200
480281	AVFD-191-100-9600-AS	198	100	191	30	55000	96000	11200
480283	AVFD-240-105-15000-AS	240	105	240	28	80000	150000	17600

The min. load is the value below which the vibration damper is not able to isolate the vibrations as it would be too rigid. The max load is the value beyond which some type of failure may occur that compromises the functionality of the vibration damper.

FLANGE BODY

Aluminium painted with nitrocellulose-based enamel in blue colour RAL 5010.

THREADED BUSHING

Black coated steel.

VIBRATION-DAMPER BODY

NBR rubber.
Hardness 30, 50, 60 Shore A ±5.

FEATURES AND APPLICATIONS

They are generally used for isolating strong vibrations, where axial holding force and resistance to compression is required.

Vibrations can cause:

- malfunctioning and reduction of the machine lifespan and/or of the adjacent ones;
- damage to health;
- noise.

They are particularly suitable for use with machine tools, presses for moulding plastics materials, special machines and shock absorption.

See High performance vibration dampers - Characteristics and selection criteria (on page -).

The deflection curves shown in the graph were obtained through static experimental tests adopting average values. !da duplicazione!

Actual values may differ by approximately ±10% from those shown in the graph.

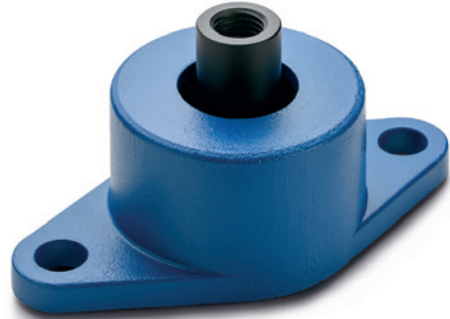

AVG-50

Compression

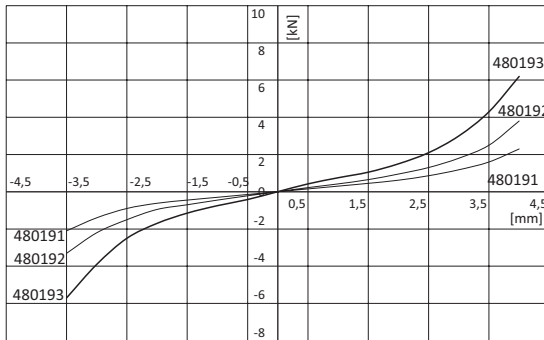

Traction

AVG-75

Compression

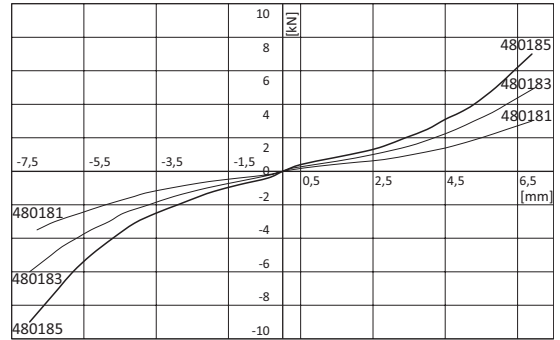

Traction

AVG-90

Compression

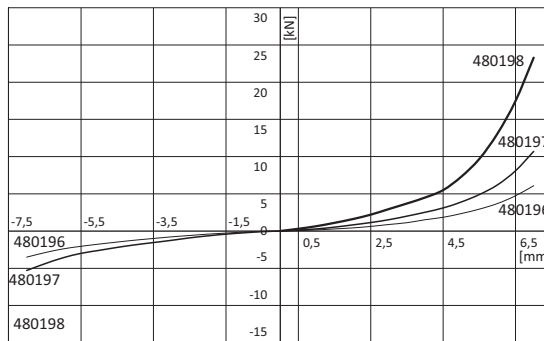

Traction

Description	Resistance to compression				Axial holding force			
	Min load [N]	Max load [N]	Min deflection [mm]	Max. deflection [mm]	Min load [N]	Max load [N]	Min deflection [mm]	Max. deflection [mm]
AVG-50-30	300	1600	1	3.5	300	1400	1	3
AVG-50-50	450	2580	1	3.5	450	2200	1	3
AVG-50-60	750	4300	1	3.5	750	3900	1	3
AVG-75-30	400	2500	1	6	400	2700	1	6
AVG-75-50	600	4000	1	6	600	4500	1	6
AVG-75-60	800	5000	1	6	800	6500	1	6
AVG-90-30	140	4800	1	6.5	140	2900	1	6.5
AVG-90-50	240	8100	1	6.5	240	4400	1	6.5
AVG-90-60	500	17500	1	6.5	500	8800	1	6.5

The min. load is the value below which the vibration damper is not able to isolate the vibrations as it would be too rigid.
 The max load is the value beyond which some type of failure may occur that compromises the functionality of the vibration damper.
 The min. deflection is the crushing of the vibration-damping support corresponding to the min. load.
 The max. deflection is the crushing of the vibration-damping support corresponding to the max. load.

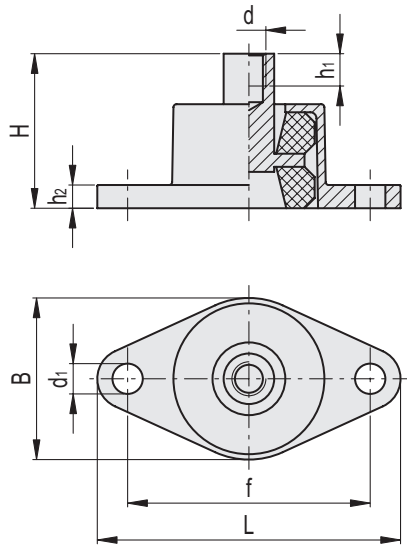

Code	Description	B	L	H	d	d1	h1	h2	f	Shore A	⚖️
480191	AVG-50-30	70	114	50	M12	11	15	6	94	30	340
480192	AVG-50-50	70	114	50	M12	11	15	6	94	50	340
480193	AVG-50-60	70	114	50	M12	11	15	6	94	60	340
480181	AVG-75-30	80	150	75	M16	15	16	10	120	30	650
480183	AVG-75-50	80	150	75	M16	15	16	10	120	50	650
480185	AVG-75-60	80	150	75	M16	15	16	10	120	60	650
480196	AVG-90-30	110	168	90	M24	17	30	12	138	30	1600
480197	AVG-90-50	110	168	90	M24	17	30	12	138	50	1600
480198	AVG-90-60	110	168	90	M24	17	30	12	138	60	1600

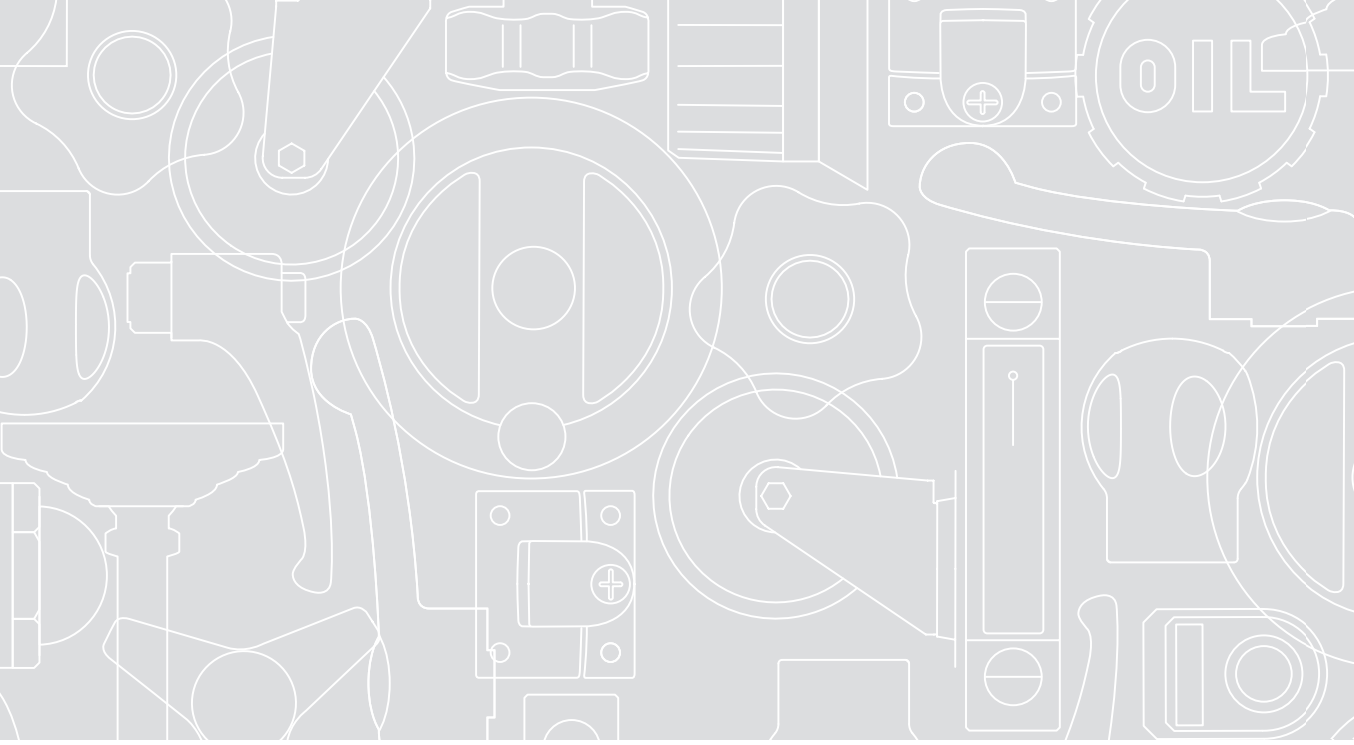

ELESA. More and more...



elesa[®]

ELESA S.p.A.
Via Pompei, 29
20900 Monza (MB) Italy
Phone +39 039 2811.1
Fax +39 039 836351
info@elesa.com

ZDEPMOUNTSENG21

elesa.com